

## Ergos 20 D/G

*I.C. counterbalanced forklift truck, full-free-view mast lifting from 3.000 to 6.000 mm, side-shift, power steering, steering column multiple adjustable, Automatic transmission. Motor Euro 3. Standard equipped with lighting, driving direction inverter at steering column, comfort driver seat enabled to absorb and limit the vibrations.*

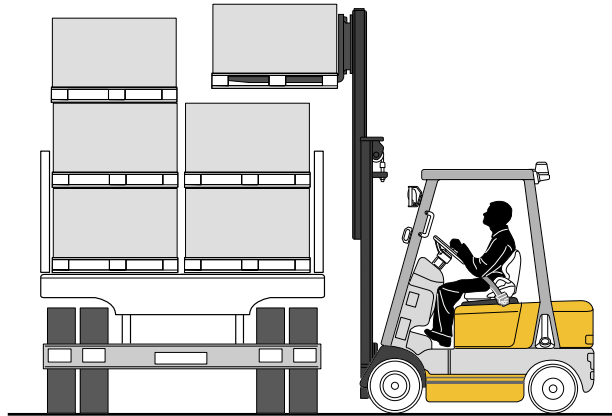

**OMG S.p.A.**  
via dell'Artigianato, 12  
46023 - GONZAGA (MN) Italy  
Tel. + 39 0376 52.60.11  
Fax. + 39 0376 58.80.08  
[www.omgindustry.com](http://www.omgindustry.com)  
[info@omgindustry.com](mailto:info@omgindustry.com)

Azienda certificata  
ISO 9001:2000



		OMG S.p.A.		
Characteristics	1.1	Manufacturer		
	1.2	Manufacturer's model designation		ERGOS 20 D      ERGOS 20 G
	1.3	Drive : D ( diesel ) G ( lpg )		D      G
	1.4	Type of control : S ( steering wheel ) R ( seated )		S / R
	1.5	Load capacity	Q ( t )	2.0
	1.6	Load centre distance	c ( mm )	500
	1.8	Load distance, centre of drive axle to fork	X ( mm )	465
	1.9	Wheelbase	Y ( mm )	1.550
	Weight	2.1	Service weight	
2.2		Axle loading ( with load )	front / rear	Kg      4.720 / 860
2.3		Axle loading ( without load )	front / rear	Kg      1.480 / 2.100
Wheels - Chassis	3.1	Tyres : se ( superelastic ) cu ( cushion ) pn ( pneumatic )		se / pn
	3.2	Front wheels size	mm	7,00 - 12 - 12
	3.3	Rear wheels size	mm	6,00 - 9 - 10
	3.5	Wheels : number front / rear ( x = traction )		2 / 2
	3.6	Track width, front	b 10 ( mm )	970
	3.7	Track width, rear	b 11 ( mm )	985
	Dimensions	4.1	Mast tilting forward / backward	
4.2		Lowered mast height		h1 ( mm )      2.150
4.3		Free lift		h5 ( mm )      1.650
4.4		Lifting height		h3 ( mm )      3.300
4.5		Extended mast height		h4 ( mm )      4.520
4.7		Overhead guard ( cab )		h6 ( mm )      2.150
4.8		Seat height		h7 ( mm )      1.140
4.12		Coupling height		h10 ( mm )      250
4.19		Total length		l1 ( mm )      3.660
4.20		Length to forks face		l2 ( mm )      2.460
4.21		Overall width	b1 / b2 ( mm )	1.158 / 1.532
4.22		Forks dimensions		s / e / l      40 / 125 / 1.200
4.23		Fork carriage Class / Type A, B		IIA
4.24		Fork carriage width		b3 ( mm )      1.024 / 1.650
Performances		4.31	Ground clearance, under the mast	laden
	4.32	Ground clearance, centre of wheelbase	laden	m2 ( mm )      196
	4.33	Aisle width with pallets 1000 x 1200 forking side 1200		Ast3 ( mm )
	4.34	Aisle width with pallets 800 x 1200 forking side 800		Ast3 ( mm )      3.860
	4.35	Turning radius		Wa ( mm )      2.170
	4.36	Smallest pivot point distance		b13 ( mm )
	5.1	Travel speed	laden / unladen	Km / h      18 / 19
	5.2	Lifting speed	laden / unladen	m / s      0.55 / 0.65
5.3	Lowering speed	laden / unladen	m / s      0.47 / 0.44	
5.5	Drawbar pull ( a 2 Km/h )	laden / unladen	N      17.100 / 13.100      13.100 / 12.00	
5.7	Gradient performance ( a 2 Km/h )	laden / unladen	%      25 / 22      20 / 19.5	
5.9	Acceleration time ( 10 m )		s	
5.10	Service brake M ( mechanical ) I ( hydraulic )		M - I	
Motor	7.1	Manufacturer / type		YANMAR 4TNE98      NISSAN K-25
	7.2	Engine power		KW      44.1      38
	7.3	Rated speed		rpm      2.450      3.200
	7.4	Number of cylinders / cubic capacity		cm³      4 / 3.319      4 / 2.488
	7.5	Fuel consumption according to VDI cycle		l / h      3.1      2.75
Others	8.1	Type of drive control		powershift 1/1
	8.2	Operation pressure for attachments		bar      185
	8.3	Oil volume for attachments ( max available )		l / min
	8.4	Sound level at driver's ear		dB ( A )      88
	8.5	Tow coupling, type DIN		
Technical specification according VDI 2198				DS.069EN.REV.02
Information and data are given for information only, OMG S.p.A. will have the sole right for technical changes and improvements without giving any notice.				

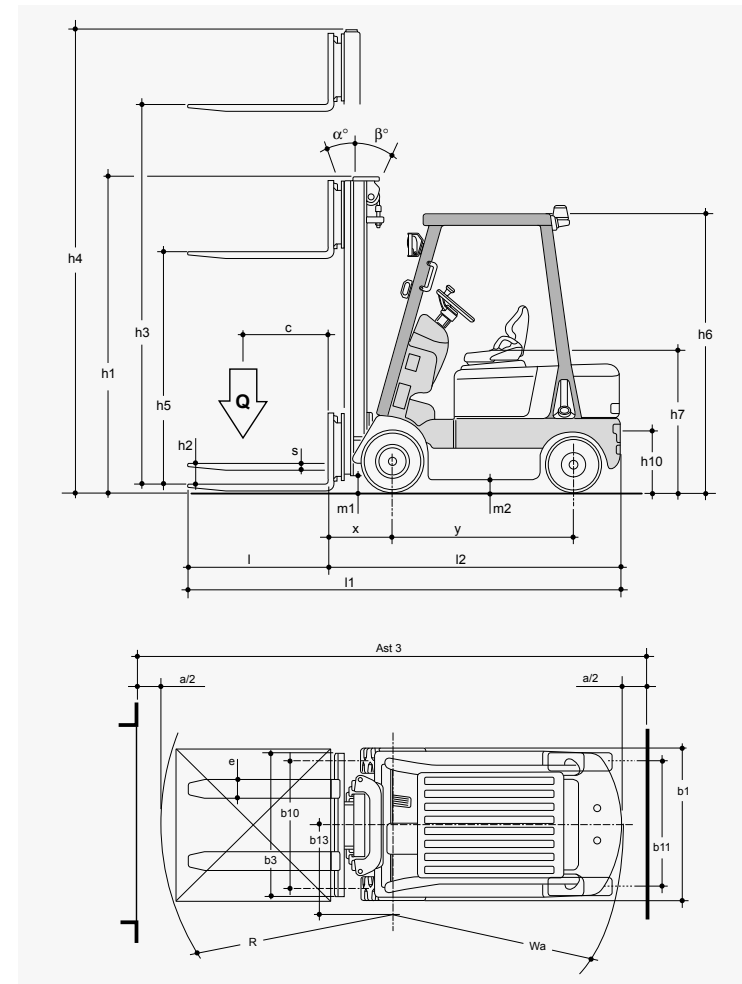

h3		h1	h4	h2	h5	(Q) t c = 500 mm	(Q) t c = 600 mm
3.000	mm	2.000	4.220	/	1.490	2.0	1.65
3.300	mm	2.150	4.520	/	1.650	2.0	1.65
3.500	mm	2.250	4.720	/	1.750	1.85	1.55
4.000	mm	2.550	5.220	/	2.000	1.85	1.55
4.500	mm	2.100	5.720	/	1.490	1.7	1.4
4.800	mm	2.150	6.020	/	1.600	1.6	1.35
5.000	mm	2.250	6.220	/	1.650	1.6	1.35
6.000	mm	2.650	7.220	/	2.000	1.5	1.25