

# Features

## EASILY CONFIGURED TO MEET YOUR NEEDS

### FORK OPTIONS

- Load platform
- Fork extensions

### POWER OPTIONS

- One-speed manual winch
- Two-speed manual winch

### BASE

- Standard base

### CASTER

- Standard casters

## OPTIONS & ACCESSORIES

### PRODUCTIVITY

- Load platform
- Fork extensions

### POWER

- Two-speed manual winch

## STANDARD FEATURES

### MEASUREMENTS

#### ST™-20

- 21 ft 2.5 in (6.46 m) maximum working height
- Up to 800 lb (363 kg) load capacity

#### ST™-25

- 26 ft .5 in (7.94 m) maximum working height
- Up to 650 lb (295 kg) load capacity

### PRODUCTIVITY

- Use as a single unit, or two or more can be used together to support trusses
- Flat black anodized finish is nearly invisible to audience
- Portable and compact design
- Lightweight, durable aluminum construction
- Single-door access
- Easy set-up with no tools required
- Durable steel forks
- Hand winch locks in place when handle is released
- Easy to transport—no bulky base
- Hold-down mechanism secures carriage during transport

### POWER

- One-speed manual winch
- Reversible winch handle for easy storage

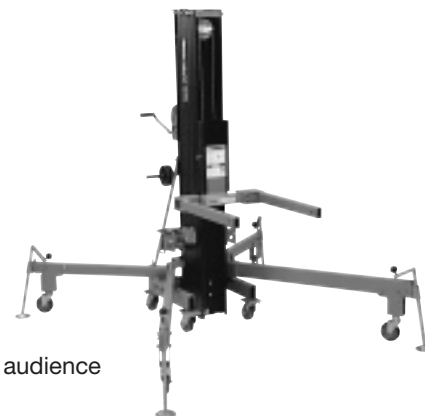

# Specifications

MODELS	ST™-20		ST™-25	
MEASUREMENTS	US	Metric	US	Metric
<b>A</b> Height - stowed	6 ft 6.75 in	2.2 m	6 ft 6.75 in	2.2 m
<b>B</b> Length - stowed	2 ft 1.25 in	.64 m	2 ft 1.25 in	.64 m
<b>C</b> Width - stowed	1 ft 10 in	.56 m	1 ft 10 in	.56 m
<b>D</b> Load height minimum	6 in	.15 m	6 in	.15 m
<b>E</b> Ground clearance - center	2 in	.05 m	2 in	.05 m
Working height - forks up	21 ft 2.5 in	6.46 m	26 ft .5 in	7.94 m
- forks down	19 ft 6 in	5.94 m	24 ft 4 in	7.42 m
PRODUCTIVITY				
Load capacity - at 18 in load center	800 lbs	363 kg	650 lbs	295 kg
Length - adjustable forks	27.5 in	.70 m	27.5 in	.70 m
Width - adjustable forks	11.5–30 in	.29–.76 m	11.5–30 in	.29–.76 m
Fork extensions detached each (l/w/d)	30/2/3 in; 4.5 lbs	76/5/8 cm; 2 kg	30/2/3 in; 4.5 lbs	76/5/8 cm; 2 kg
Fork extensions attached each (l/w/d)	25/2/3 in; 4.5 lbs	64/5/8 cm; 2 kg	25/2/3 in; 4.5 lbs	64/5/8 cm; 2 kg
Weight - adjustable forks	52.5 lbs	24 kg	52.5 lbs	24 kg
Outrigger footprint	73.5 x 79.5 in	1.87 x 2.02 m	73.5 x 79.5 in	1.87 x 2.02 m
Casters	standard casters		standard casters	
POWER				
Average cranks: standard winch	8.5 cranks/ft	27.8 cranks/m	8.5 cranks/ft	27.8 cranks/m
two speed winch, high	4 cranks/ft	13.1 cranks/m	4 cranks/ft	13.1 cranks/m
two speed winch, low	15 cranks/ft	49.2 cranks/m	15 cranks/ft	49.2 cranks/m
WEIGHT*				
	507 lbs	230 kg	555 lbs	252 kg

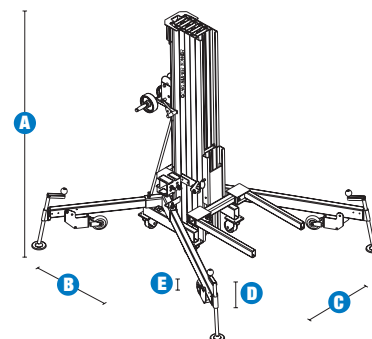

\* Weight will vary depending on options and/or country standards.

## Genie United States

18340 NE 76th Street  
P.O. Box 97030  
Redmond, Washington 98073-9730  
Telephone **+1 (425) 881-1800**  
Toll Free in USA/Canada **+1 (800) 536-1800**  
Fax +1 (425) 883-3475

## Genie Europe

Millennium House  
Brunel House  
Newark NG24 2DE  
UK  
Telephone **+44 (0)1476 584333**  
Fax +44 (0)1476 584334  
Email: infoeurope@genieind.com

## Distributed By:

Effective Date: January, 2009. Product specifications and prices are subject to change without notice or obligation. The photographs and/or drawings in this document are for illustrative purposes only. Refer to the appropriate Operator's Manual for instructions on the proper use of this equipment. Failure to follow the appropriate Operator's Manual when using our equipment or to otherwise act irresponsibly may result in serious injury or death. The only warranty applicable to our equipment is the standard written warranty applicable to the particular product and sale and we make no other warranty, express or implied. Products and services listed may be trademarks, service marks or trade-names of Terex Corporation, Genie Industries, Inc. and/or their subsidiaries in the U.S.A. and many other countries and all rights are reserved. Terex is a Registered Trademark of Terex Corporation in the U.S.A. and many other countries. Genie is a Registered Trademark of Genie Industries, Inc. in the U.S.A. and many other countries. Genie is a Terex Company. © 2009 Terex Corporation.